

Instruction book

SK 98840-6I



Refrigerator

Instructions for the use of the instructions booklet



Notes which are important for your safety or for the proper functioning of the appliance



Supplementary information regarding operation and practical applications of the appliance.



Tips and notes concerning economical and environmentally sound use of the appliance



The symbol on the product or on its packaging indicates that this product may not be treated as household waste. Instead it shall be handed over to the applicable collection point for the recycling of electrical and electronic equipment. By ensuring this product is disposed of correctly, you will help prevent potential negative consequences for the environment and human health, which could otherwise be caused by inappropriate waste handling of this product. For more detailed information about recycling of this product, please contact your local city office, your household waste disposal service or the shop where you purchased the product.

Contents

Safety Instructions.....	4
Diposal	6
Use and Control / Before Use	7
Temperature Setting Buttons	7
Starting up and temperature regulation	8
SUPERCOOL.....	10
Internal parts /	12
Door shelves.....	12
Hints.....	13
Maintenance	14
Defrosting	16
Regular cleaning.....	17
How to change the bulb.....	18
Something not Working	19
Customer Service and Spare Parts.....	20
Installation	20
Positioning	21
Electrical connection.....	22
Building-in.....	23



Safety Instructions

This information has been provided in the interests of your safety. Please read it before installing or using the appliance. Please retain the instruction book for future reference. If ownership is transferred, please leave the user manual for the new owner.

Domestic Use

- Keep these instructions and make sure that they remain with the appliance when moving away or changing owner.
- This appliance is designed for storing food, domestic use and being used according to these instructions only.
- **Your authorised Service Centre must carry out service and repairs including repairing and changing the power cord.** Accessory parts supplied by them should be used only for repairing. Otherwise the appliance can be damaged or can cause other damage or injury.
- The plug must only be removed if the power supply to the appliance has been switched off. Before cleaning and maintenance always unplug the appliance (do not pull the plug by the cable). If the socket is difficult to reach, switch off the appliance by turning the power supply off.
- The power cable must not be lengthened.
- **Make sure that the cable is not squashed or damaged by the back of the refrigerator.**
 - A damaged power plug may overheat and cause a fire.
- **Do not place heavy articles or the fridge/freezer itself on the power cord.**
 - There is a risk of a short circuit and fire.
- **Do not remove the power cord by pulling on its lead, particularly when the fridge/freezer is being pulled out of its niche.**
 - Damage to the cord may cause a short-circuit, fire and/or electric shock.
 - If the power cord is damaged, it must be replaced by a certified service agent or qualified service personnel.
- **If the power plug socket is loose, do not insert the power plug.**
 - There is a risk of electric shock or fire.
- Without the lamp cover of interior lighting you must not operate the appliance.
- When cleaning, defrosting, taking out frozen food or ice tray do not use sharp, pointed or hard devices, as they can cause damage to the appliance.

- Be careful not to allow liquids to the temperature control and lighting box.
- Ice and ice-cream can cause hurt if they are eaten immediately after removal from the frozen food compartment.
- After defrosting frozen food must not be refrozen, it must be used up as soon as possible.
- Store pre-packed frozen food in accordance with the frozen food manufacturer's instructions.
- You must not make defrosting faster with any electric heating appliance or chemicals.
- Do not place any hot materials such as a baking tray near the plastic components of your appliance.
- Do not store flammable gas and liquid in the appliance, because they may explode.
- Do not store carbonated drinks, bottled drinks and bottled fruits in the frozen food compartment.
- Check and clean the outlet for the defrost water regularly. If this becomes clogged then this can cause faults with your appliance.

Precautions for child safety

- Do not allow children to play with the packaging of the appliance. Plastic foil can cause suffocation.
- Adults must handle the appliance. Do not allow children to play with it or its controlling parts.
- If you are discarding the appliance pull the plug out of the socket, cut the connection cable (as close to the appliance as you can) and remove the door to prevent playing children to suffer electric shock or to close themselves into it.
- This appliance is not intended for use by persons (including children) with reduced physical sensory or mental capabilities, or lack of experience and knowledge, unless they have been given supervision or instruction concerning use of the appliance by a person responsible for their safety.



Environment Protection

- This appliance does not contain gasses which could damage the ozone layer, in either its refrigerant circuit or insulation materials. The appliance shall not be discarded together with the urban refuse and rubbish. Avoid damaging the cooling unit. Information on your local disposal sites may be obtained from your municipal authorities.

- Remove the plug and ensure that any locks or catches are removed, to prevent young children being trapped inside.



Disposal

Appliance Packaging Information

The materials marked with the symbol  are recyclable.

>PE< for polyethylene, e.g. sheet wrapping material

>PS< for polystyrene, e.g. padding material (always CFC-free)

>POM< polyoxymethylene, e.g. plastic clips.

All materials are environmentally sound!

Safety precautions for isobutane

Warning

- The refrigerant of the appliance is isobutane (R600a) this is a flammable substance.
- Keep ventilation openings, in the appliance enclosure or in the built-in structure, clear of obstruction.
- Do not use mechanical devices or other means to accelerate the defrosting process, other than those recommended by the manufacturer.
- Do not damage the refrigerant circuit.
- Do not use electrical appliances inside the food storage compartments of the appliance, unless they are of the type recommended by the manufacturer.



Use and Control

Before Use



Wait 4 hours before connecting the appliance to allow the oil to flow back in the compressor.

- Before using the appliance for the first time, wash the interior and all internal accessories with lukewarm water and some neutral soap so as to remove the typical smell of a brand-new product, then dry thoroughly.



Do not use detergents or abrasive powders, as these will damage the finish.

- Remove safety elements used for transportation.

Control panel

- 1 Pilot light (green)
- 2.ON/OFF switch
- 3.Temperature setting buttons (for warmer temperatures)
- 4.Temperature display
- 5.Temperature setting buttons (for colder temperatures)
- 6.FROSTMATIC function "on" indicator (yellow)
 - FROSTMATIC for freezing items quickly in the freezer compartment
- 7.Push button for FROSTMATIC
- 8.COOLMATIC function "on" indicator (yellow)
 - COOLMATIC for intensive fridge cooling
9. Push button for COOLMATIC

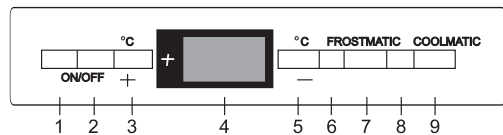

Temperature Setting Buttons

The temperature is adjusted using the "+" (WARMER) and "-" (COLDER) buttons.

These buttons are connected to the temperature display.

- The temperature display is switched over from the display of the ACTUAL temperature (temperature display is illuminated) to the display of the

DESIRED temperature (temperature display flashes) by pressing one of the two buttons, "+" or "-".

- With each further press of one of the two buttons, the DESIRED temperature is adjusted by 1°C.
- If neither button is pressed, the temperature display automatically switches back after a short period (approx. 5 sec.) to the display of the ACTUAL temperature.

DESIRED temperature means:

The temperature that is required in the refrigerator, this can be adjusted to the temperatures shown in the display. The DESIRED temperature is indicated by flashing numbers.

ACTUAL temperature means:

The temperature display indicates the temperature that is currently present in the refrigerator. The ACTUAL temperature is indicated by continuously illuminated numbers.

Temperature Display



The temperature display can indicate several pieces of information.

- During normal operation, the temperature currently present in the refrigerator (ACTUAL temperature) is displayed.
- When the temperature is being adjusted, the temperature currently set flashes (DESIRED temperature).

Prior to Initial Start-Up

Please clean the appliance interior and all accessories prior to initial startup (see section: "Cleaning and Care").

Starting up and temperature regulation

1. Insert the plug into the plug socket. When the refrigerator compartment door is opened, the internal lighting is switched on.
2. Press ON/OFF button. The green mains pilot indicator illuminates.
3. Press either the "+" (WARMER) or "-" (COLDER) button. The temperature display switches over and the DESIRED temperature currently set flashes on the temperature display.

4. Set the required temperature by pressing the "+" (WARMER) or "-" (COLDER) buttons (see section "Temperature setting buttons"). The temperature display will immediately show the changed setting. With each further press of one of the two buttons, the DESIRED temperature is adjusted by 1°C. Adjustable temperature range: +2°C to +8°C.

i **Note:** From a food safety point of view, +5°C for the refrigerator compartment should be considered cold enough as a storage temperature.

5. Once the required temperature has been set, after a short period (approx. 5 sec.) the temperature display will change and again indicate the current ACTUAL temperature inside the fridge.

The display will change from flashing to continuous illumination. The compressor will start and then run automatically.

Information! When the setting is changed, the compressor does not start immediately if automatic defrosting is currently taking place.

i As the storage temperature within the fridge is reached quickly you can store food immediately after switching on.

Important! Wait until the freezer compartment has reached a temperature of -18 °C, before storing frozen food.

COOLMATIC/FROSTMATIC

COOLMATIC Button

The COOLMATIC function is suited for quick cooling of large quantities of goods in the refrigerator, e.g. drinks and salads for a party.

1. The COOLMATIC function is switched on by pressing the COOLMATIC button. The yellow light illuminates.
2. The COOLMATIC function now ensures intensive cooling. A DESIRED temperature of +2°C is automatically selected. The COOLMATIC function is ended automatically after a period of 6 hours. The originally selected DESIRED temperature is again valid and the compartment will return to. The temperature display shows the ACTUAL refrigerator temperature.
3. The COOLMATIC function can be ended manually at any time by pressing the COOLMATIC button again. The yellow light goes out.

FROSTMATIC Button

The FROSTMATIC function accelerates the freezing of fresh food and, at the same time, protects foodstuffs already stored from undesirable warming.

1. The FROSTMATIC function is switched on by pressing the FROSTMATIC button. The yellow light illuminates.
If the FROSTMATIC function is not ended manually, the appliance electronics switch off the FROSTMATIC function after 24 hours. The yellow light goes out.
2. The FROSTMATIC function can be ended manually at any time by pressing the FROSTMATIC button again. The yellow light goes out.

 When the FROSTMATIC function is switched on the ACTUAL temperature in the fridge can fall slightly.

Once the FROSTMATIC function has been switched off the selected DESIRED temperature will be resumed.

 **Warning:** The COOLMATIC and FROSTMATIC functions cannot be switched on simultaneously.

If the COOLMATIC or FROSTMATIC functions are switched on the temperature setting may not be changed.

Switching off the Appliance

To switch off, press the ON/OFF button for approx.3 seconds. This will result in a countdown from "3" to "1" taking place in the temperature display. On reaching "1" the fridge will switch off. The temperature display will go off.

Note: The appliance cannot be switched on or off if unplugged, or if there is no power being supplied to it. Following connection to the mains power supply, the appliance returns to the same operating state as before the interruption of main power.

If the appliance is not going to be used for an extended period:

1. Remove all frozen and refrigerated packages.
2. Switch off the appliance by holding down the ON/OFF button until the display goes off (see above).
3. Remove the mains plug or switch off or disconnect from the electricity supply.
4. Defrost the freezer compartment and clean thoroughly (see section: "Cleaning and Care").
5. Leave the doors open to avoid build up of odours.

Temperature indicator

The temperature indicator gives a variety of information.

- During normal operation, it shows the temperature inside the refrigerator compartment. (actual temperature).
- When setting the temperature, the temperature set for the refrigerator compartment (nominal temperature) at that moment blinks.

Caution: as many as 24 hours may be required before the temperature indicator shows the actual temperature.

SUPERCOOL function

The SUPERCOOL function speeds up the cooling of fresh food products while at the same time protecting those already stored from undesirable heating. A nominal temperature of +2°C is automatically pre-set.

- The function turns on by pressing the SUPERCOOL button (I). The yellow indicator (H) lights up.
- It is possible to stop this function at any time by pressing the SUPERCOOL button once again. The yellow indicator turns off.
- If the SUPERCOOL function does not stop manually, it is automatically cut off electronically after about 6 hours.

The SUPERCOOL function is deactivated if the electric current is cut off!

Temperature

There are different temperature zones in the refrigerator compartment. The warmest zone is at the top, and the coldest zone is above the cover of the vegetable bins.

The internal temperature is influenced by the following factors:

- Room temperature
- How often the door is opened
- Amount of food products stored
- Appliance setting

Internal Parts

Storage shelves

- The shelves can be removed for cleaning.
- To permit storage of food packages of various sizes, the shelves can be placed at different heights.
- To remove the internal shelf pull forward until it can be tipped up or down and removed.
- Please do the same in reverse to insert the shelf at a different height.
- For better use of space, the front halfshelves can lie over the rear ones.

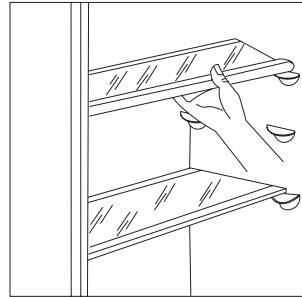

Door shelves

- To permit storage of food packages of various sizes, the central door shelf can be adjusted in height.
- Gradually pull the shelf in the direction of the arrows until it comes free, then reposition as required.
- For more thorough cleaning, the top and bottom door shelves can be removed by pulling them in the direction of the arrows, then refitting them in position.

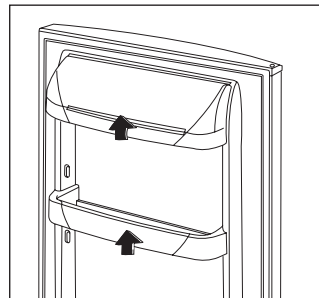

Hints

Saving Energy

- Pay careful attention to where the cabinet is placed. See the section Installation. When installed correctly the cabinet will consume less energy.
- Try to avoid keeping the doors open for long periods or opening the doors too frequently as warm air will enter the cabinet and cause the compressor to switch on unnecessarily often.
- If the ambient temperature is high, the thermostat knob is on the coldest setting (higher numbers) and the appliance is fully loaded, the compressor may run continuously, causing frost or ice to form on the evaporator. If this happens, turn the knob to a warmer setting (lower numbers) to allow automatic defrosting and so a saving in electricity consumption.
- Do not place warm foods inside the appliance. Allow warm foods to cool first.
- Keep the heat emitting condenser, the metall grille on the rear wall of your appliance, always clean.

Hints for refrigeration

- Do not store warm food or evaporating liquids in the refrigerator and do cover or wrap up the food, particularly if it has a strong smell.

To help you use your refrigerator correctly, here are some useful hints:

- **Raw meat (beef, pork, lamb & poultry):** wrap in polythene bags and place on top of the salad compartment, this being the coldest spot in the refrigerator. **Meat can only be stored safely in this way for one or two days at the most.**
- **Cooked food, cold cuts, jelly, etc.:** these should be well covered and can be stored on any of the glass shelves.
- **Fruit & vegetables:** these should be thoroughly cleaned and placed in the bottom drawer/s.
- **Butter & cheese:** these should be placed in special airtight containers or wrapped in aluminium foil or polythene bags to keep out as much air as possible.
- **Milk bottles:** these should have a top and should be stored in the bottle rack on the door.

Bananas, potatoes, onions and garlic, if not packed, must not be kept in the refrigerator.

Maintenance



Unplug the appliance before carrying out any maintenance operation.



Warning

This appliance contains hydrocarbons in its cooling unit maintenance and recharging must therefore only be carried out by authorised technicians.

Storing foods

Make sure that cold air can circulate when storing foods.

The products to be cooled must never be in direct contact with the rear wall inside the refrigerator compartment.

They can freeze and partially remain stuck to the wall when removed, thus preventing the dew from flowing regularly.

Place foods such as cheese, cold cuts, fruit, vegetables, previously cooked foods and prepared

salads inside containers and cover them.

In this way their natural freshness and aroma will be maintained.

Foods must be stored according to the various temperature zones.

Butter, cheese - in the inner door inside the butter dish and cheese holder.

Eggs

- in the inner door

Fruit, vegetables, lettuce

- in the vegetable bins

Cold cuts, meat

- in the bottom zone (first shelf or covering above the vegetable bin)

Dairy products, preserves, jars

- in the top zone or in the inner door

Bottles / tubes

- in the inner door

Using the freezer compartment

Important!

Do not open the refrigerator if you suffer a power cut. Food does not spoil if the appliance is full and the power cut lasts a short time (see further information under "Preservation time in case of failure" in the brochure or advertising material). If the power cut is longer than this time then the food must be used up within a short period.

Preservation time drops when the temperature of the frozen foods increases.

Temperature adjustment

To set the temperature, use the relevant buttons for both the refrigerator and freezer compartments. See "Using the refrigerator compartment" The right temperature for frozen foods and those to be frozen is -18°C .

SUPERFROST function

The SUPERFROST function speeds up the freezing of fresh food products while at the same time protecting those already inside the compartment from undesirable heating.

- The function turns on by pressing the SUPERFROST button (G). The yellow indicator (F) lights up.

- It is possible to manually stop this function at any time by pressing the SUPERFROST button once again.

The yellow indicator turns off.

- If the SUPERFROST function does not stop manually, it is automatically cut off electronically after about 24 hours.

The yellow indicator turns off.

The SUPERFROST function is deactivated if the electric current is cut off!

Temperature of the freezer

The internal temperature is influenced by the following factors:

- Room temperature
- How often the door is opened
- Amount of food products stored
- Appliance setting

Caution: Check the state of the frozen foods if the freezer compartment heats up.

Freezing foods

To freeze foods, turn on the SUPERFROST function 24 hours before freezing. Just 4-6 hours are needed for a lower quantity.

Freezer compartment equipment

Defrosting

A certain amount of frost will always form on the cooling compartment.

Thick frost and ice has an insulating effect, so it reduces cooling efficiency as the temperature increases, it needs more energy, at a certain thickness it does not allow the door of the frozen food compartment to open, possibly the door can be broken.

At this type of appliance defrosting fresh food compartment is automatic without any external intervention.

The thermostatic control interrupts the operation of compressor at regular intervals for more or less time - during this cooling is interrupted - temperature of the fresh food compartment increases and defrosting occurs. After defrosting the thermostatic control restarts operation of the system.

Melting water flows through defrost water outlet into the evaporative tray maintained on the top of compressor and evaporates due to warmth of it.



Check the defrost water outlet for any blockages and clean it regularly. If it is clogged the defrost water gathered can cause a fault with the appliance as it can affect the insulation of the appliance.

Clean the defrost water outlet with the supplied pipe cleaner that can be seen in the figure. The pipe cleaner has to be stored in the outlet.

Occasionally check that the defrost water has not become clogged up.

The most common cause of clogging up in the defrost water outlet is from packaging from food, therefore care should be taken when placing food with packaging inside the appliance.

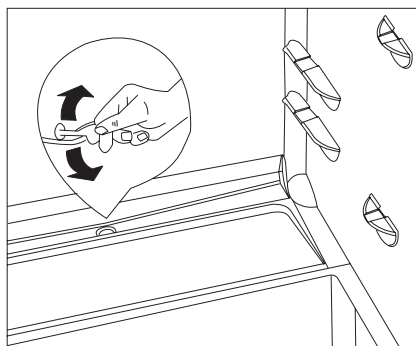



In case of higher temperatures e.g. during heat waves, the refrigerators compressor may operate more regularly to keep the appliance cool.

Some remaining ice and frost may still be visible on the back plate of the cooling compartment after the defrosting period, this is completely normal. The frozen food compartment can not be equipped with automatic defrosting set since the deep-frozen and frozen foods do not endure melting temperature.

Provided it is not too thick, the layer of frost or ice can be scraped off and removed using a plastic scraper.

When ice coating is so thick that it can not be removed with the plastic scraper, the frozen food compartment has to be defrosted (generally 2-3 times a year).

Take the foods out of the frozen and fresh food compartment, wrap them into some layers of paper or cloth. Put them in a cool area while defrosting. Turn off the power to the appliance and leave the doors ajar.

Continuously blot off the defrosting water by using a soft cloth or sponge.

After defrosting wipe the surfaces, apply voltage to the appliance and put the foods back to their places.

It is recommended to operate the appliance at the highest position of the thermostatic control so that it can reach the proper storing temperature as soon as possible.

Regular cleaning

It is recommended to wash the inside of the refrigerator in 3-4 weeks time.

Household cleaner or soap must not be used.

After you made it no-current wash the appliance using lukewarm water and wipe it.

Clean the magnet door rubber profile with clean water.

After cleaning plug the appliance to the mains socket.

It is practical to clean and defrost the frozen food compartment at a time and when it is empty.

Dust and dirt collected on the back of the refrigerator and the condenser should be removed once or twice a year. At the same time, the evaporative tray on top of the compressor should be cleaned as well.

When the refrigerator is not in use

In case the appliance will not be used for a long time follow these steps:

Turn off the power to the appliance.

Remove foods from the refrigerator.

Defrost and clean it as written before.

Leave the door open to avoid a build up of air inside.

How to change the bulb

1. Turn off the power to the appliance.
2. Unscrew the lamp cover securing screw.
3. Unhook the moving part by pressing it as shown in the figure.
4. Replace the bulb with one of the same power (the maximum power is shown on the light bulb cover)
5. Fix the lamp cover in place.
6. Screw the lamp cover securing screw.
7. Reconnect the appliance.
8. Open the door and check if the light comes on.

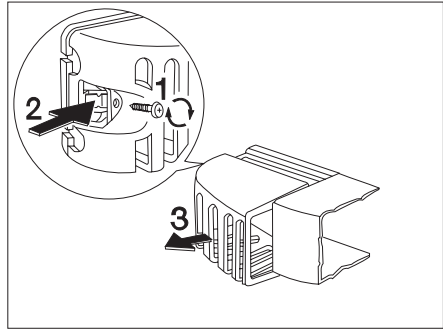

Something not Working

Faults may be due to problems which can easily be solved by yourself before calling the Service Force engineers. Please follow these instructions.

SYMPTOM	SOLUTION
Door does not close	Weight surpasses the storage limit of the door shelf so spread weight more evenly or take some products out. The appliance is not properly installed. Please look in the Building-in. section.
It is too warm inside the refrigerator	Set a lower temperature. Distribute the food products to allow cold air to circulate around them. Make sure that the door is completely closed and that the insulating strip is complete and clean. The temperature where the cabinet is placed is above normal room temperature.
It is too cold inside the refrigerator.	Set a warmer temperature.
The compressor works continuously.	Set a warmer temperature. The temperature where the cabinet is placed is above normal room temperature. Check that the ventilation is sufficient and that the ventilation openings are unobstructed. The cause could be the introduction of large quantities of food and/or frequent opening/closing of the door.
Noises	Sometimes this is normal. Temperature control may cause clicking sounds when the system is connected or disconnected. The injected cooling gas may produce a gurgling sound while passing through the tubes. The motor may cause a humming noise and/or slight bumping. The insulation material used has a tendency to slightly increase noise levels, how ever it allows for much better insulation and a lower energy consumption.

Malfunctions

If the electronics in the appliance have detected a fault that prevents the ACTUAL temperature being measured, the temperature display shows a square. The appliance will continue to function using a backup programme until your local Customer Service engineer has repaired the appliance.

Customer service and spare parts

If you cannot find the remedy for a malfunction in these operating instructions, please contact your dealer or our customer service department and consult the Guarantee card.

Selective ordering of replacement parts can save unnecessary travel and costs.

For this reason always provide the following appliance information:

- **Model Name**
- **Product Number (PNC)**
- **Serial Number (S-No.)**

This information can be found on the rating plate inside the cabinet on the left hand wall. We recommend that you enter this information here, so that it is handy if needed.

Technical specifications

The technical data is indicated in the rating plate on the left side inside the appliance.



If there is a power failure when food is in the freezer, do not open the door of the freezer compartment.

The frozen food will not be affected if the power cut is of short duration (up to 12 hours) and the freezer compartment is full, otherwise, it is recommended that the food should be used within a short time (a temperature increase of the frozen food shortens its safe storage period).

Installation

Take utmost care when handling your appliance so as not to cause any damages to the cooling unit with consequent possible fluid leakages.

- During normal operation, the condenser and compressor at the back of the appliance heat up considerably. Always ensure that there is adequate ventilation as a failure to do this will result in component failure and possible food loss. See installation instructions.
- Important: if the supply cord is damaged, it must be replaced by a special cord or assembly available from the manufacturer or its service agent.

Positioning

- Unpack the cabinet and check that it is in good condition and free of any transport damage.
 - The appliance must not be located close to radiators or gas cookers.
 - Avoid prolonged exposure of the appliance to direct sunlight.
 - For safety reasons, minimum ventilation must be as shown in Fig.
- Attention: keep ventilation openings clear of obstruction.

- It is necessary that the niche is provided with a conduct of ventilation having the following dimensions:

Depth 50 mm

Width 540 mm

The climate classification can be found on the rating plate, which is located inside the cabinet on the left hand wall.

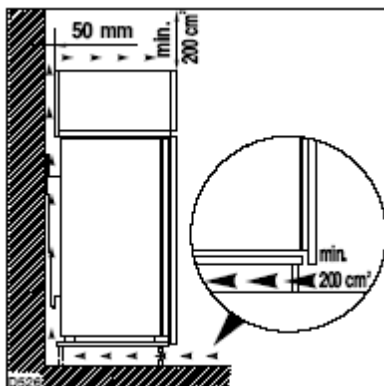

The following table shows which ambient temperature is correct for each climate classification:

Climate classification	for an ambient temperature of
SN	+ 10... + 32 °C
N	+ 16... + 32 °C
ST	+ 16... + 38 °C
T	+ 16... + 43 °C

When the ambient temperature is not included within the range indicated for the class of this appliance, the storage temperature in the appliance cannot be guaranteed; therefore it is advisable to use the food stored as soon as possible.

Electrical Connection



Any electrical work required to install this appliance should be carried out by a qualified electrician or competent person.

This appliance must be earthed.

The manufacturer declines any liability should these safety measures not be observed.

Electrical Requirements

Before switching on, make sure the electricity supply voltage is the same as that indicated on the appliance rating plate.

The appliance is supplied with a 13 amp plug fitted. In the event of having to change the fuse in the plug supplied, a 13 amp ASTA approved (BS 1362) fuse must be used. Should the plug need to be replaced for any reason. The wires in the mains lead are coloured in accordance with the following code:

Green and Yellow: Earth

Blue: Neutral

Brown: Live

The wire coloured green and yellow must be connected to the terminal marked with the letter "E" or by the earth symbol  or coloured green and yellow.

The wire coloured blue must be connected to the terminal "N" or coloured black.

The wire coloured brown must be connected to the terminal marked "L" or coloured red.

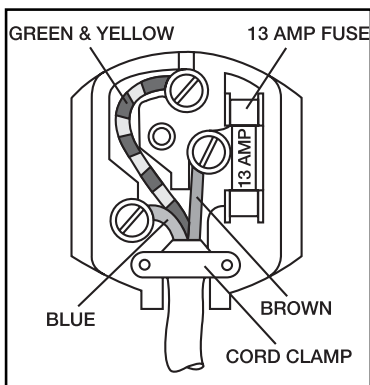

Upon completion there must be no cut, or stray strands of wire present and the cord clamp must be secure over the outer sheath.



Important!

The plug must still be accessible after the appliance has been installed.

The appliance should not be connected to the electrical supply by means of an extension cable.

In case that the electrical cable has to be replaced, please contact your local Service Force Centre.

Warning!

A cut off plug inserted into a 13 amp socket is a serious safety (shock) hazard. Ensure that it is disposed of safely.

CE This appliance complies with the following E.E.C. Directives:

- 73/23 EEC of 19.02.73 (Low Voltage Directive) and subsequent modifications,
- 89/336 EEC of 03.05.89 (Electromagnetic Compatibility Directive) and subsequent modifications.
- 96/57 EEC - 96/09/03 (Energy Efficiency Directive) and its subsequent amendments

Building-in

Dimensioned drawing

See "Installation Instructions"

Please check whether, after installing your appliance and especially after reversing the door, the door seal seals right round. A badly fitting door seal may lead to heavy frosting and thereby to a higher power consumption.

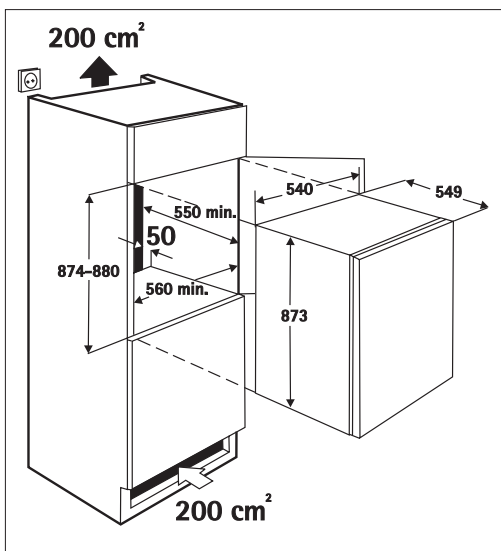

AEG Hausgeräte GmbH
Postfach 1036
D-90327 Nürnberg

Sie können Ersatzteile, Zubehör und Pflegemittel on-line bestellen bei
<http://www.aeg-electrolux.de>

© Copyright by AEG

Technische Änderungen vorbehalten

200382487- 00 - 2509